

CONVEYOR LC

Conveyor
for METAL SHARK® Metal Detectors
product weight max. 6 kg

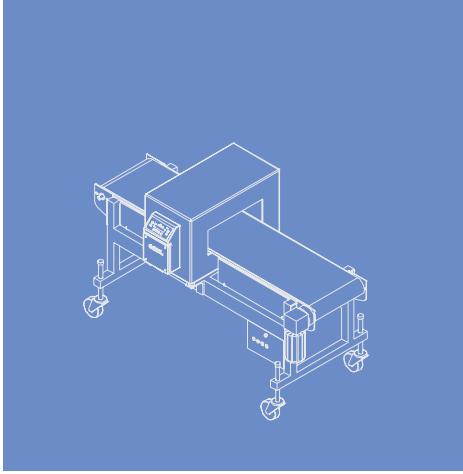

Cassel takes great pride in the engineering and manufacturing of their series LC conveyors to compliment their METAL SHARK® metal detectors.

The conveyor's design has been adapted to the special requirements of metal detectors to provide optimum operation.

Solid Construction

All Cassel conveyors are constructed of high quality Stainless Steel rectangular tubing. All welds are inspected for quality and solid construction.

Hygienic

All welds are ground and polished to provide a clean surface. Welded inserts in the support frame prevent water entry into the frame.

Conveyor Controls

Conveyor Controls are conveniently located in one Stainless Steel enclosure. START, STOP and RESET buttons are located on the enclosure for ease of operation. Optional key reset switches can be provided to allow security of the monitoring of metal detector reset due to company policy of HACCP requirements.

Variable Frequency Drives

Hitachi (220 VAC) or Allen Bradley (110 VAC) are available as optional equipment.



Conveyor system LC

Cassel offers with the LC a conveyor that is special designed for low weight product inspection of max. 6 kg. The LC is installed into an existing production line. The complete system is ready for operation immediately after installation.

The LC conveyor is made of sturdy stainless-steel, appropriate for use in food industry. They are maintenance-free and constructed for a durable operation in an industrial environment.



Technical Data

Conveyor length	800 mm (without reject)
Line height	800 mm +/-50mm
Design	Stainless steel 304, rectangular tubing, Polyurethan belt white
Metal Detector	prepared for METAL SHARK BD assembly
Motor	Groschopp gear motor drive, 3 Ph, 40W (German high quality brand motor)
Beltspeed	24 m/min.
Belt width	400 mm
Product weight	max. 6 kg
Reject	Stop on detect, buzzer alarm
Options	Drop-End conveyor for reject, 400 mm length Reject bin, mobile with castors Protective cover, transparent

Head quarters:
Cassel Messtechnik GmbH
In der Dehne 10
37127 Dransfeld / Germany
Tel. ++49-5502-91150
Fax ++49-5502-911532
www.cassel.de info@cassel.de

CASSEL

METAL SHARK

CE

www.cassel.de

CONVEYOR LC

Conveyor
for METAL SHARK® Metal Detectors
product weight max. 6 kg

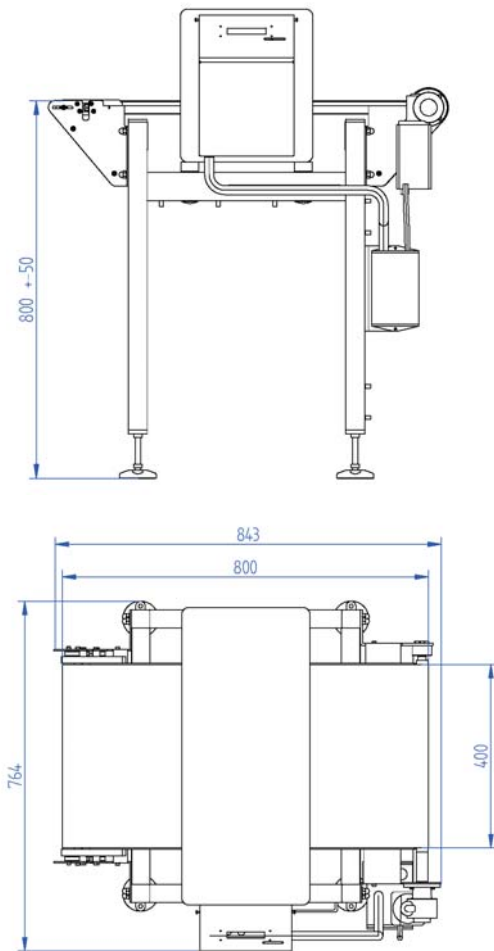

LC 0800x0400 PU

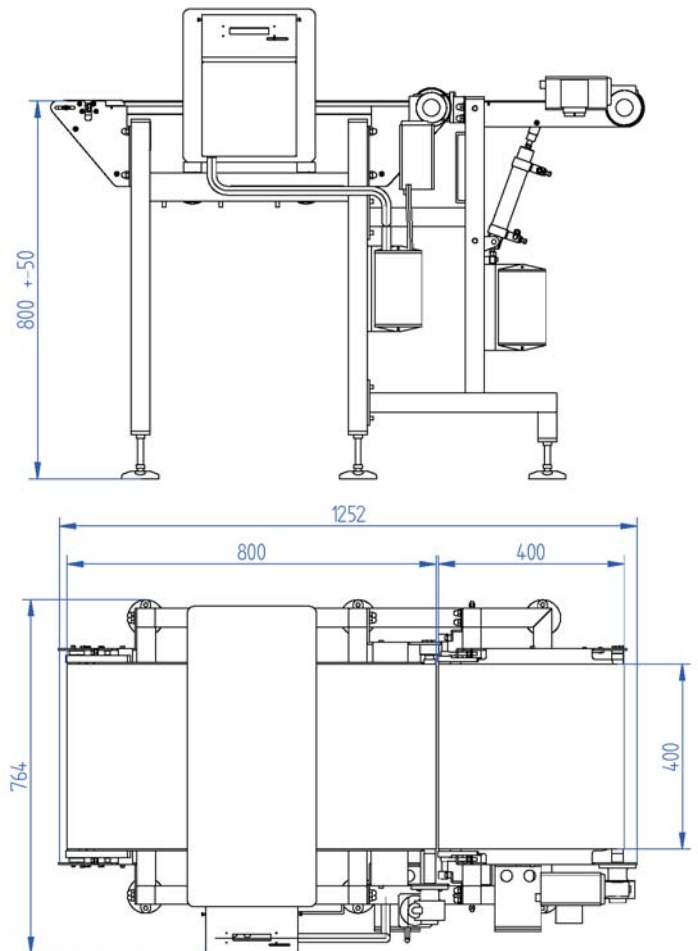

LC 0800x0400 PU with Drop End reject